



Main features

Printing type



Barcode



Logos



Alphanumeric text

Maximum height



0-15 mm



16-100 mm



Above 100 mm

Printing surfaces



Primary packaging



Secondary packaging



Raw material

- Ergonomic industrial cabinet AISI 304 with high environmental protection, fully compatible with egg grading machines (MOBA).
- Up to 5 lines with height range from 0.8 to 14 mm with Micro Print Nozzle for high quality resolution print.
- Very low consumption thanks to an efficient vapour condenser.
- Advanced hydraulic system for quick and easy start up with automatic visible double flushing, also indicated for production lines with long stops.
- Wide range of inks for printing on eggs.

Z5000 EGGS

TECHNICAL SPECIFICATIONS

PRINTING CHARACTERISTICS

- Up to 5 lines of print
- Characters height from 0,8 to 14 mm (0,032" - 0,56")
- Line speed capability: up to 400 mt/min (1320 ft/min)
- Print rate: up to 2136 ct/sec
- 250 messages storage
- Up to 250 characters storage per message
- Selectable lines vertical gap
- Font Matrix: 5x4, 5x5, 7x4, 7x5, 9x7, 10x8, 15x10, 16x10, 24x16 and 32x18
- Bold factor up to 8 times
- Simple Logo creation and printing
- 50 Logos storage
- Automatic calendar and expiration date print
- Incrementing/decreasing product counters up to 9 digits
- Repeat print – message function
- Printing in all moving directions
- Tower print function (Text rotation of 90°)
- DIN print for cables sector (optional)
- Negative print function
- Coding throw distance up to 90 mm (3,54")

BAR CODES

- 2/5 Industrial, UPC-A, CODE 39, EAN 13 CODE 128 (A,B,C), EAN 128 (A,B,C) 2D - Datamatrix, ITF (A,B,C)

CONTROL UNIT CHARACTERISTICS

- Membrane keyboard solvent resistant
- Blue WYSIWYG Display with high contrast 240x128 pixels
- Stainless Steel structure AISI 304
- Protection IP65
- Conduit length: 4 mt (13,1 ft)

GENERAL FEATURES

- Single Start/Stop button
- Vapour recovery system for low make up consumption
- Advanced hydraulic system for quick and easy start up with automatic cleaning
- Print parameters storage in the messages
- Keypad access with password
- Operator selectable foreign language prompts
- User-friendly and intuitive operator interface
- Several foreign languages
- Report function for executed printing counter
- Message storage with alphanumeric text

PRINTHEAD

- Stainless steel and aluminium structure hermetically sealed
- Micro Print Nozzle for high quality resolution print
- Auto-phasing of ink stream for consistent print quality
- Microjet nozzle cleaning function
- Wide range of inks for printing on eggs
- Dimensions: 227 mm x 42 mm x 49 mm (9,0" x 1,7" x 1,9")
- Conduit inlet at 90° (optional)
- Internal Supply Positive Air Function
- 90° model for reduced/short spaces (optional)

EXTERNAL CONNECTIONS

- Serial connection RS232 and RS485/422
- Ethernet interface for LAN connection (optional)
- Sensor management for product reading
- Interface for moving printhead management
- System ready output
- Shaft Encoder input for variable speed production lines
- External alarm outputs with traffic light column
- Parallel interface BCD
- Compatibility with egg grading machines (MOBA)

ENVIRONMENT/ELECTRICAL REQUIREMENTS

- Temperature: from 5° to 45°C (40°-113°F)
- Humidity: 10 - 90% (non-condensing)
- Single Phase, 85-240 Vac, 50-60 Hz, 85 VA

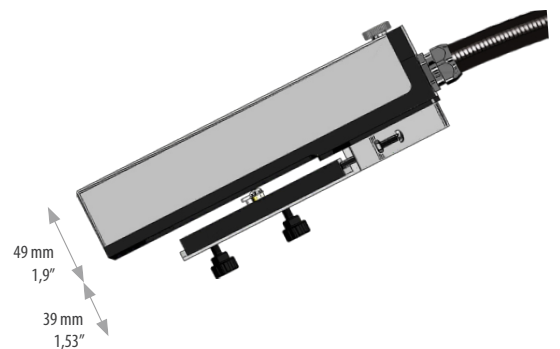
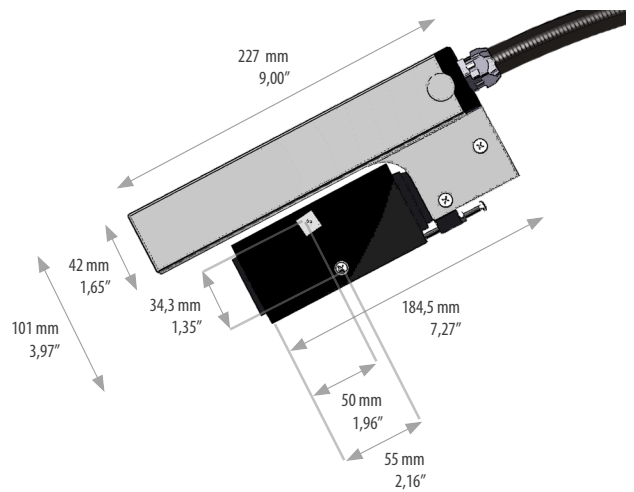
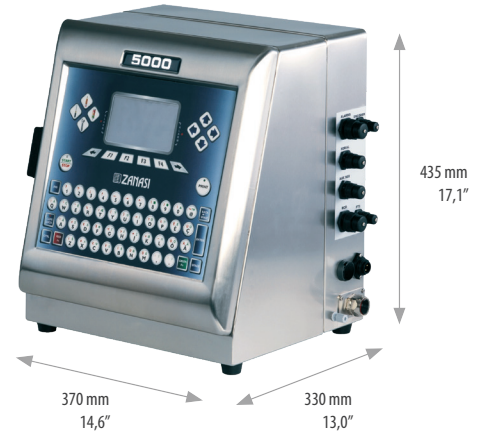

Use a QR code reader to see the product page